



# ESX MobiLeveler®

*The Bishamon ESX MobiLeveler®  
Provides the Ergonomic Advantage  
of Self-Leveling Operation and the  
Convenience of Mobility*



Learn More at: [indoff.bishamon.com](http://indoff.bishamon.com)

Experience Industry's  
"Best Engineered"  
Ergonomic Equipment

MobiLeveler® Selector Chart

Model	Travel (in)	Collapsed Cap. Range (lbs)		Height (in)		Table Sizes (in)		Overall Size (in)			Shipping Weight (lbs)
		Min.	Max.	Min.(A)	Max.(G)	Width (C)	Length (D)	Width(E)	Length(F)	Height(B)	
ESX-10	15.8	66	220	10.4	26.2	17.8	27.6	17.8	33.3	31.3	90
ESX-21	16.6	175	460	13.8	30.4	19.8	32.3	19.8	40.0	35.5	170
ESX-40	16.6	220	880	14.5	31.1	20.5	39.8	20.5	48.5	35.5	280

MobiLeveler® ESX

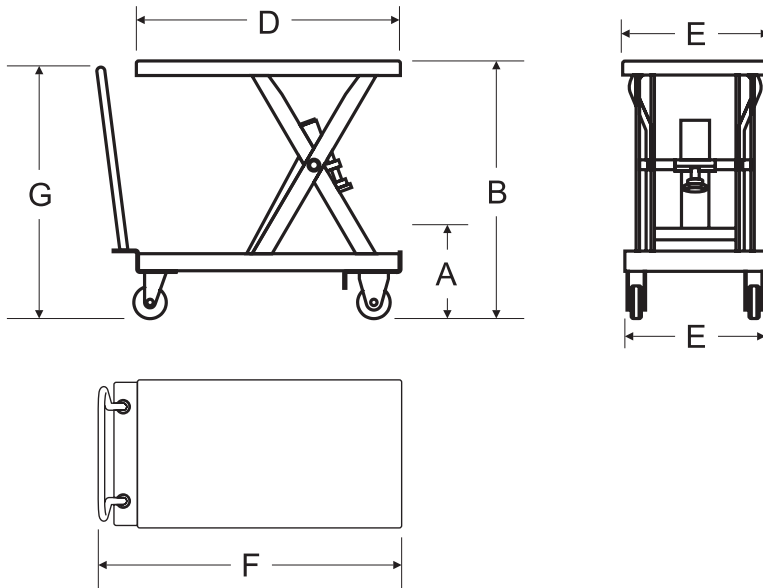

## Standard Features

- Self-leveling, load weight compensating
- Easily accessible gauged weight-selector knob
- Single and dual spring models
- Heavy-duty maintenance, scissor locking pin
- High quality casters with brake
- Steel work platforms
- Rugged construction, with heavy-gauge steel and sturdy welds throughout
- Clean design with minimum maintenance required
- Durable powder-coated finish



High-quality casters with locking brake for smooth transport

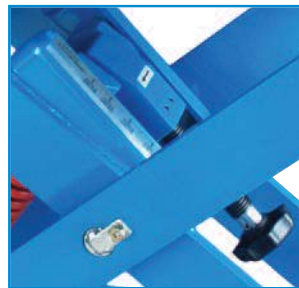

Convenient gauged weight selector knob for adjusting spring resistance



Heavy-duty locking pin prevents the unit from lowering for maintenance

### Warranty :

Bishamon Industries Corporation warrants its products to be free from defects in material and workmanship for a period of one (1) year from the date of initial shipment. This warranty shall not apply to any misuse, mishandling, accident, shipping, alteration, or unauthorized repair of any Bishamon product or part. For complete details of warranty, please contact Indoff at: 800-950-6438.

DISTRIBUTED BY:

**Indoff**

4300 Land O' Lakes Blvd., Land O' Lakes, FL 34639  
 (813)996-6443 Fax (877)507-2119 (800)950-6438  
[terry@indoff-fl.com](mailto:terry@indoff-fl.com) [www.indoff-fl.com](http://www.indoff-fl.com)

