

# EZ Loader<sup>®</sup>

Automatic Pallet Positioner

**Bishamon**<sup>®</sup>

## New! Now one adjustable model will handle most of your pallet loading/unloading needs!



Protected by U.S. and foreign patents Other patents pending

We took the unparalleled EZ Loader and made it even more user friendly!

The new EZ Loader will now handle a wide range of weight capacities from 250 lbs. up to 4,000 lbs.

To make it even better, we added the EZ Adjust knob - a three-position knob that allows adjustment of the collapsed capacity without changing the air pressure!

EZ Loaders are designed to eliminate worker bending by automatically raising and lowering pallets during loading or unloading without the use of mechanical springs, motors or hydraulics. EZ Loaders also allow easy pallet rotation for near-side loading so the worker does not have to reach or strain. As the load weight changes, the EZ loader automatically adjusts keeping the top of the load at a convenient working height. The patented pneumatic system found only on the EZ Loader has proven to be the choice of industry professionals worldwide.



Stainless Steel Model



Pressure Gauge & EZ Adjust Knob

**Indoff**

**Material Handling Equipment**

4300 Land O' Lakes Blvd., Land O' Lakes, FL 3463

(813)996-6443 Fax (813)996-1128 (800)950-6438

[busingco@gte.net](mailto:busingco@gte.net)

[www.busingcoinc.com](http://www.busingcoinc.com)

Warranty - Bishamon Industries Corp. ("Bishamon") warrants its products to be free from defects in material and workmanship for a period of one (1) year from the date of initial shipment. This warranty shall not apply to any misuse, mishandling, accident, shipping, alteration, or unauthorized repair of any Bishamon product or part. For complete details of warranty, please contact Bishamon at 800-358-8833.



# EZ Loader<sup>®</sup>

Automatic Pallet Positioner

Working Harder To  
Make Your Life Easier

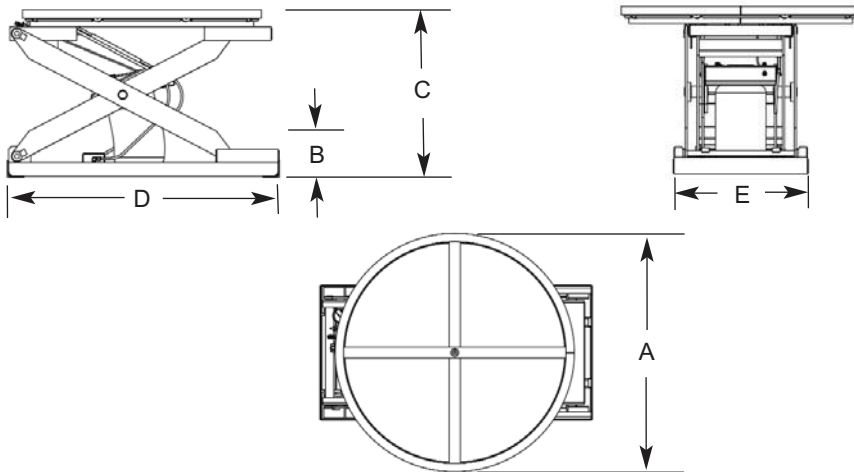

## EZ Loader Specifications

(A) Rotator Ring Diameter = 43.0 inches (1092 mm)  
 (B) Lowered Height = 10.5 inches (267 mm)  
 (C) Raised Height = 30.5 inches (775 mm)  
 (D) Base Frame Length = 49.0 inches (1245 mm)  
 (E) Base Frame Width = 24.3 inches (617 mm)  
 Minimum Self Leveling Capacity = 250 lbs (113 kgs)  
 Maximum Self Leveling Capacity = 3500 lbs (1588 kgs)  
 Maximum Load Capacity = 4000 lbs (1814 kgs)  
 Travel = 20.0 inches (508 mm)  
 Air Pressure Capacity Adjustment = Infinite (10 – 60 psi / 0.7 – 4.1 bar)  
 On-board Capacity Adjustment = 3 position knob (light – medium – heavy)

## EZ Loader Models

EZ LOADER	Standard powder coated finish
EZ LOADER-E	FDA compliant powder coated finish with stainless solid round top
EZ LOADER-SS	Grade 304 stainless steel with electro-polished finish

## EZ Loader Accessories

EZ-BRK	Rotator ring brake to prevent rotation
EZ-ABS	Accordion bellows skirting with frame
EZ-SLP	Semi-live portability for moving unloaded lift (2 wheels & dolly handle)
EZ-CART	Cart portability with 2 swivel and 2 rigid wheels (add 7" to lowered height)
EZ-SRT	Solid 43" diameter round top
EZ-4444	Oversize rectangular rotating platform (44"x44")
EZ-4448	Oversize rectangular rotating platform (44"x48")
EZ-4848	Oversize rectangular rotating platform (48"x48")
EZ-SRT-DNT	Solid 43" diameter round top with 90 degree detents
EZ-4444-DNT	Oversize rectangular rotating platform (44"x44") with 90 degree detents
EZ-4448-DNT	Oversize rectangular rotating platform (44"x48") with 90 degree detents
EZ-4848-DNT	Oversize rectangular rotating platform (48"x48") with 90 degree detents

## Standard Features:

- Self leveling design automatically keeps the top of the load at a convenient working height to help eliminate bending and improve productivity
- Integral rotator ring helps eliminate reaching and stretching
- Captive air operation eliminates cumbersome mechanical springs and gives more controlled (dampened) movement of the platform
- A three position EZ Adjust knob allows adjustment of the collapsed capacity without changing air pressure
- Secured ball bearing center pivot of the 43" diameter rotator ring provides smooth, even rotation
- Pressure relief valve prevents excess pressure build-up
- Surfaces are phosphatized and powder coated with a high quality polyester for a lasting, durable finish
- Rollers are entrapped in the base frame and platform for added stability
- A safety finger guard eliminates pinch points with the rotator spoke and bearings
- Integral maintenance blocks
- EZ Loaders arrive at your facility fully assembled - just add air!
- Easily transported with a fork truck or via optional portability packages
- The EZ Loader is CE marked under the Machinery Directive (2006/42/EC)

DISTRIBUTED BY:

**Indoff**

4300 Land O' Lakes Blvd., Land O' Lakes, FL 34639  
 (813)996-6443 Fax (813)996-1128 (800)950-6438  
[busingco@gte.net](mailto:busingco@gte.net) [www.busingcoinc.com](http://www.busingcoinc.com)

## EZ Loader<sup>®</sup> Specifications

*(US & Foreign Patents Pending)*

### Specifications:

- Minimum Self Leveling Capacity = 250 lbs (113 kgs)
- Maximum Self Leveling Capacity = 3500 lbs (1588 kgs)
- Maximum Load Capacity = 4000 lbs (1814 kgs)
- Lowered Height = 10.5 inches (267 mm)
- Raised Height = 30.5 inches (775 mm)
- Travel = 20.0 inches (508 mm)
- Base Frame Width = 24.3 inches (617 mm)
- Base Frame Length = 49.0 inches (1245 mm)
- Air Pressure Capacity Adjustment = Infinite (10 – 60 psi / 0.7 – 4.1 bar)
- On-board Capacity Adjustment = 3 position knob (light – medium – heavy)

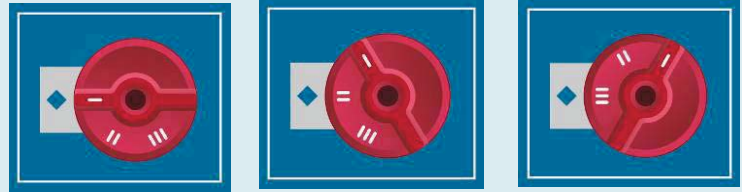
Air Pressure Setting (psi)			
	Load to Collapse (lbs)		
15	300	550	800
55	1400	2000	2700

Note: The chart above illustrates the on-board capacity adjustability of the new EZ Loader<sup>®</sup>. For **ANY** air pressure setting, the new EZ Loader has three (3) collapsed capacity settings; light (-), medium (=) and heavy (≡). A capacity change can be made at any time without the need to add or remove air and is as easy as turning a knob.

- Maximum Internal Air Pressure = 135 psi (9.3 bar)
- Shop Air Requirements = Clean dry air 60 psi (4.1 bar)
- Turntable = 43 inch diameter with 8 precision ball bearings on the perimeter
- Turntable Center Pivot = 1 precision ball bearing
- Air Spring = Two ply fabric reinforced rubber
- Sound Pressure Level = <70dB(a)
- Operating Environment = Indoors
- Operating Environment Temperature = +30°F to +120°F (-1.1°C to +48.9°C)
- Lighting Requirement = Good general lighting
- Finish = Powder coated steel
- Product Weight = 380 lbs (172 kgs)
- Approximate Shipping Weight = 450 lbs (204 kgs)



## EZ Loader<sup>®</sup> Options

*(US & Foreign Patents Pending)*

### Options & Accessories

- Brake Bolt on Rotator Ring Brake
- Bellow Bolt on Bellows Guard
- SL Portability Bolt on Semi-Live Portability
- Solid Rd Top Rotator Ring with Solid Round Top
- Platform Square and Rectangular Platforms

## EZ Loader<sup>®</sup> Features

### New Product Features *(all existing product features remain current)*

- 3 position capacity adjustability without changing air pressure
- Easily adjusts for varying load weights
- Easily adjusts for varying worker heights
- Improved performance with light loads *(250 lbs capacity)*
- Designed to work in conjunction with Bishamon's UniLift<sup>®</sup>
- Custom easy-to-read air gauge

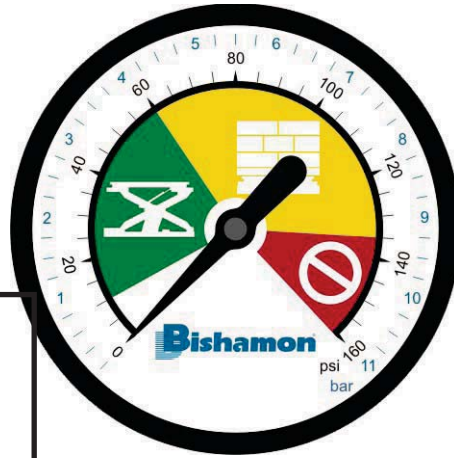

*EZ Loader consisting of FDA compliant epoxy paint and stainless steel rotating platform. (Not recommended for wash-down applications)*



*EZ Loader constructed of 304 stainless steel for food and washdown applications.*

# Indoff

4300 Land O' Lakes Blvd., Land O' Lakes, FL 34639  
(813)996-6443 Fax (813)996-1128 (800)950-6438  
[busingco@gte.net](mailto:busingco@gte.net) [www.busingcoinc.com](http://www.busingcoinc.com)



The EZ Loader's automatic self-leveling operation with integral rotator ring provides the ultimate in ergonomics while helping to increase worker productivity.

### ***Ideal For Loading and Unloading Applications!***



### **DESIGN FEATURES & BENEFITS**

- Self-leveling design automatically keeps the top of the load at a convenient working height to help eliminate bending and improve productivity
- Integral rotator ring helps eliminate reaching and stretching
- Captive air operation eliminates cumbersome mechanical springs and gives more controlled (dampened) movement to the platform
- 3 position adjustability without changing air pressure
- Pressure gauge and air valves are protected, yet located for easy access  
The custom air gauge indicates pressure in English and metric scales
- Secured ball-bearing center pivot of the 43" dia. rotator ring provides smooth, even rotation
- Pressure relief valve prevents excess pressure build-up
- Heavy-duty structural steel construction to handle tough industrial environments
- Surfaces are phosphatized and powder coated with a high-quality polyester for a lasting, durable finish
- Rollers are entrapped in the base frame and platform for added stability
- Safety finger guards under the rotator ring are standard on all EZ Loaders
- EZ Loaders arrive at your facility fully assembled – just add air!
- Easily transported with a fork truck or optional portability packages

## EZ-40 Specification Drawing

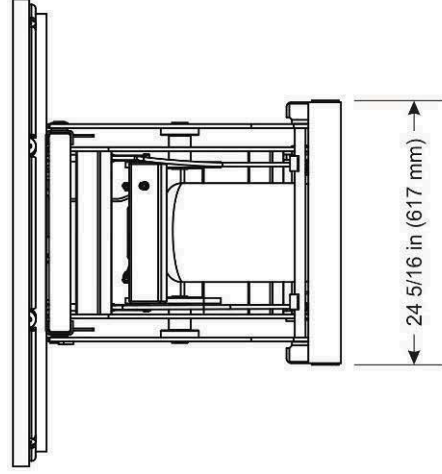
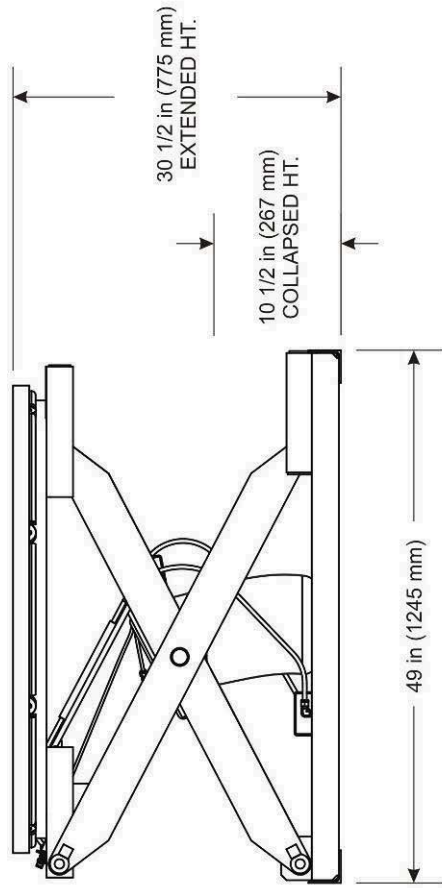
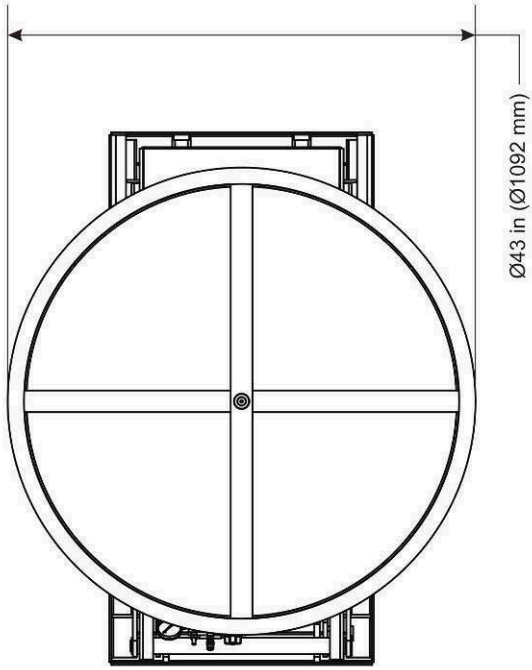

49 in (1245 mm)

24 5/16 in (617 mm)